

CIRCUIT BREAKER 1000

Pyrotechnic circuit breaker for high-voltage applications in electric vehicles

- Provides irreversible secure separation over full current range
- Low internal resistance
- Suppressed emissions
- High insulation resistance after activation



Key functional parameters

Separation capacity (voltage current inductance)	900 V 30 kA 5 μ H 900 V 20 kA 15 μ H (higher/alternative values on request)
Separation time	< 2 ms (typical <1 ms)
Operating temperature	-40 °C to +120 °C*
Ambient temperature	-40 °C to +85 °C
Product lifetime	15 years**
Qualification	in accordance with LV 123 and LV 124
Weight	410 g

*for a limited time interval

**operating hours depending on temperature collective & activation energy

HV connection (busbar)

Busbar - igniter - insulation resistance	> 50 M Ω (before and after activation)
Busbar resistance	\leq 70 $\mu\Omega$ (before activation) > 50 M Ω (after activation)
Busbar material	copper + Sn plating (alternatives on request)
Busbar cross-section area	16 mm \times 4 mm
Intended type of connection	screwing (M6)
Distance between screw holes	98 mm

LV connection (igniter)

Terminal type	Pin type (2 pins), gold-coated
11 mm Squib-Interface (unsealed)	AK-1/AK-2/ABX-5 following ISO 19072-1 commonly used: AK-2 Code I with shorting clip
Pyrotechnics	GTMS igniter (LV16 & USCAR-28), maximum pyrotechnic mass 118 mg
Igniter resistance	2.1 Ω \pm 0.4 Ω
Igniter parameter "No fire"	\leq 0.4 A \leq 5 A for \leq 4 μ s
Igniter parameter "All fire"	1.75 A to 40 A for 0.5 ms \geq 1.2 A for \leq 2 ms

Current carrying capacity*

Ambient temperature	Current	Duration
+85 °C	370 A	Continuous current
+60 °C	430 A	Continuous current
+60 °C	1100 A	70 s
+60 °C	800 A	3 min
+60 °C	500 A	20 min

*depending on cooling, convection, cross-section, contact surface etc. (thermal model upon request)

Typical curves

Typical current i and voltage u curves

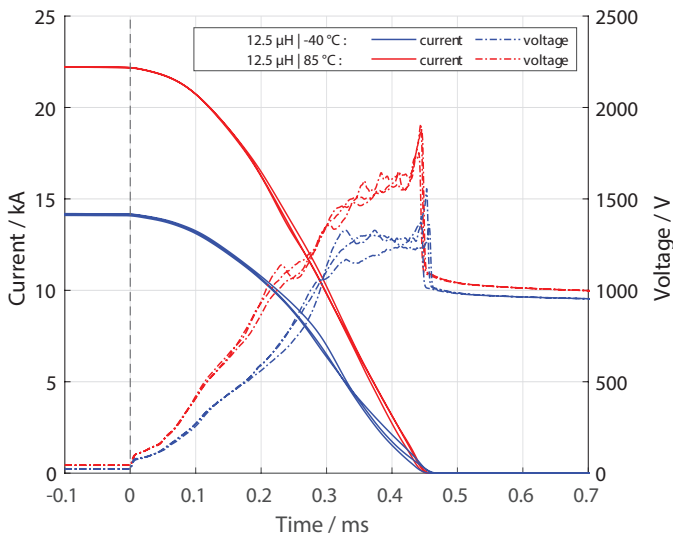

Estimated maximum switching capacity

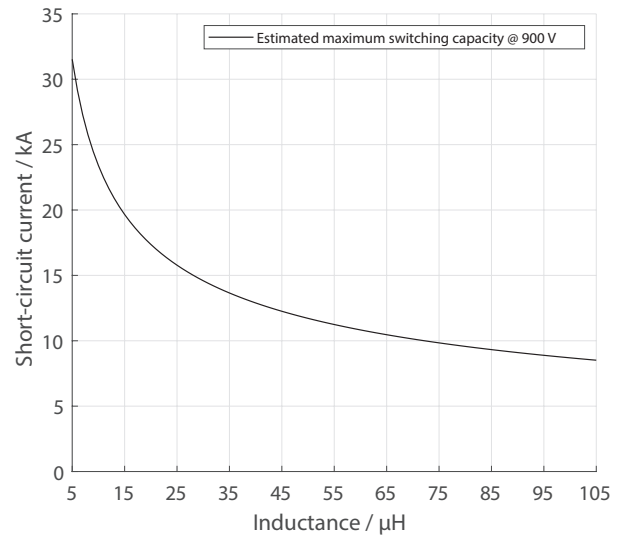

Outline dimensions*

*in mm

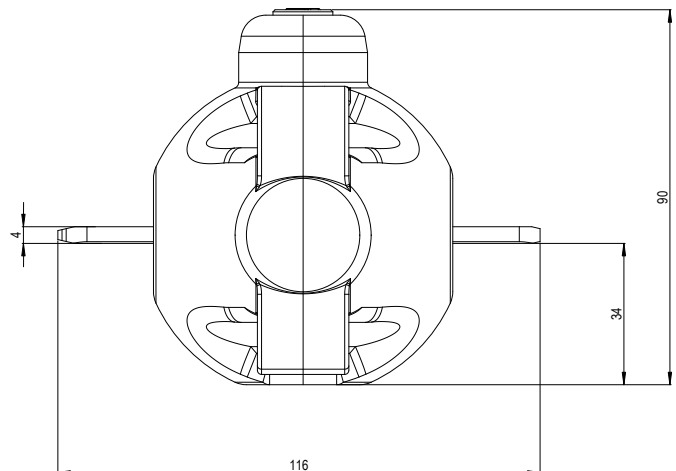
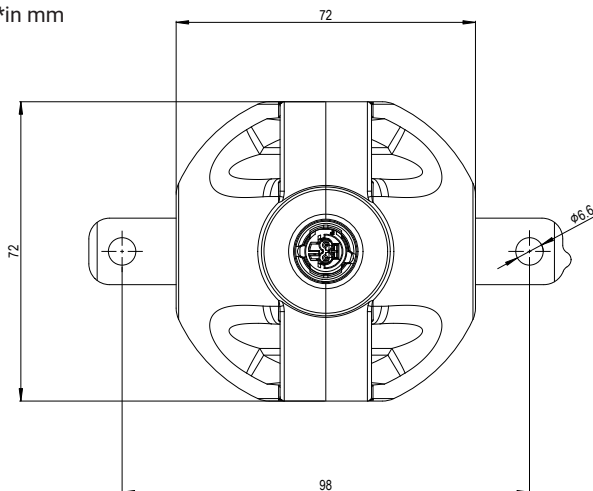

version: August 2022

