

CIRCUIT BREAKER 60-2

Pyrotechnic circuit breaker for low-voltage applications

- Prevents fires caused by short circuits and protects the electric system
- Provides irreversible secure separation over full current range
- Low internal resistance
- High insulation resistance after activation
- Lightweight design at small formfactor
- Weldable busbar connection possible



Key functional parameters

Separation capacity (voltage current inductance)	60 V 2 kA 15 μ H (higher/alternative values on request)
Separation time	< 2 ms (typical < 1 ms)
Operating temperature	-40 °C to +120 °C*
Ambient temperature	-40 °C to +85 °C
Product lifetime	15 years**
Qualification	in accordance with LV 123 and LV 124
Weight	~ 50 g

*for a limited time interval

**operating hours depending on temperature collective & activation energy

HV connection (busbar)

Busbar - igniter - insulation resistance	> 50 M Ω (before and after activation)
Busbar resistance	\leq 90 $\mu\Omega$ (before activation) > 50 M Ω (after activation)
Busbar material	copper, copper + Ni/Sn plating (alternatives on request)
Busbar cross-section area	16 mm \times 2 mm
Intended type of connection	screwing (M8)/welding
Distance between screw holes	64 mm

LV connection (igniter)

Terminal type	Pin type (2 pins), gold-coated
11 mm Squib-Interface (unsealed)	AK-1/AK-2/ABX-5 following ISO 19072-1
Pyrotechnics	GTMS igniter (LV16 & USCAR-28), maximum pyrotechnic mass 48 mg
Igniter resistance	2.1 Ω \pm 0.4 Ω
Igniter parameter "No fire"	\leq 0.4 A \leq 5 A for \leq 4 μ s
Igniter parameter "All fire"	1.75 A to 40 A for 0.5 ms \geq 1.2 A for \leq 2 ms

Current carrying capacity*

Ambient temperature	Current	Duration
+85 °C	250 A	continuous

*depending on cooling, convection, cross-section, contact surface etc. (thermal model upon request)

Typical curves

Typical current and voltage curves

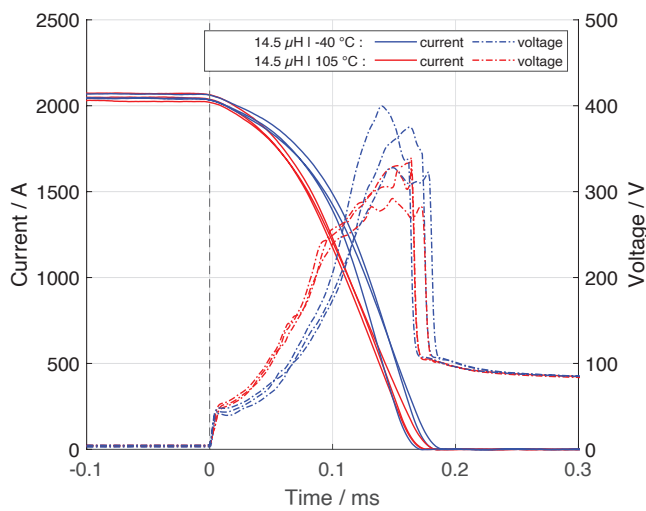

Estimated maximum switching capacity

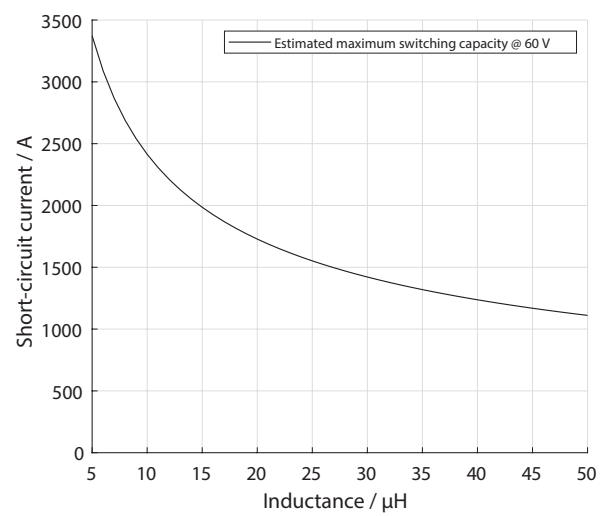

Outline dimensions*

*in mm

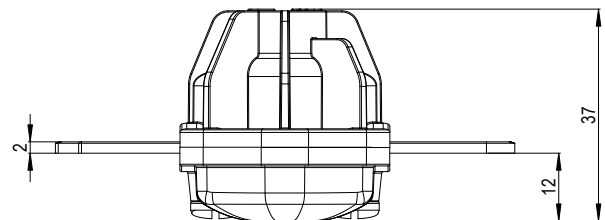
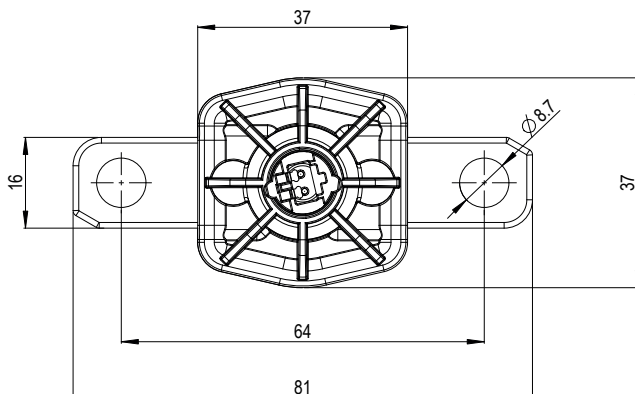

Any data, information, know-how, and any associated intellectual property shall be owned by Astotec. Astotec reserves the right to change, update or correct, without notice, the contents of this datasheet. Please note that its contents are not intended as binding specifications of the product, but rather as general information. Should you come across any errors or omissions we encourage you to contact us for further assistance. The information provided in our technical data sheets is to the best of our knowledge correct but not all-inclusive and without warranty. All rights reserved.



Astotec Automotive GmbH
 Leobersdorfer Straße 31-33
 2552 Hirtenberg /Austria
 +43 2256 811 84
automotive.at@astotec.com
automotive.astotec.com