

CIRCUIT CLOSER 500

**Pyrotechnic circuit closer for high-voltage applications in electric vehicles.
Closing switch for a secure and permanent electrical connection activated by a trigger signal.**

- Provides irreversible secure connection
- High insulation resistance before activation
- Low internal resistance after activation
- Lightweight design at small formfactor
- No emissions
- Operating Voltage 500 V

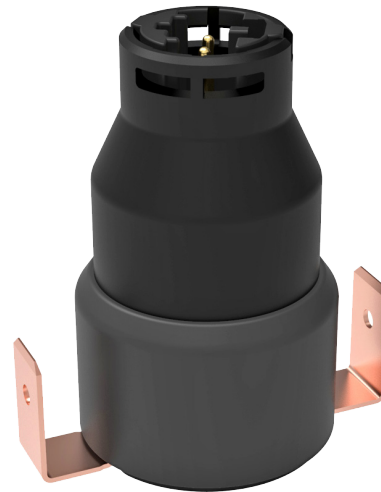

Key functional parameters

Continuous & peak current after activation	300 A for 0,5 s + 4 kA for 5 ms (superimposed) (higher/alternate values on request)
Operating voltage	500 VDC
Switching time	<1 ms
Operating temperature	-40 °C to +95 °C
Ambient temperature	-40 °C to +85 °C
Storage temperature	+5 °C to +40 °C
Product lifetime	15 years*
Qualification	in accordance with LV 123 and LV 124
Weight	20 g

*operating hours depending on temperature collective & activation energy

HV connection (busbar)

Busbar - igniter - insulation resistance	> 100 MΩ (before and after activation)
Busbar resistance	< 10 mΩ (after activation) > 100 MΩ (before activation)
Busbar material	copper + Ni/Sn plating (alternatives on request)
Intended type of connection	FastOn mating receptacle: 6.35x0.5 mm (PN: 63442-1)

LV connection (igniter)

Terminal type	Pin type (2 pins), gold-coated
11 mm Squib-Interface (unsealed)	AK-1/AK-2 following ISO 19072-1 commonly used: AK-1 Code A
Pyrotechnics	GTMS igniter (LV16 & USCAR-28), maximum pyrotechnic mass 43 mg
Igniter resistance	$2.1 \Omega \pm 0.4 \Omega$
Igniter parameter "No fire"	$\leq 0.4 \text{ A}$ $\leq 5 \text{ A for } \leq 4 \mu\text{s}$
Igniter parameter "All fire"	1.75 A to 40 A for 0.5 ms $\geq 1.2 \text{ A for } \leq 2 \text{ ms}$

Typical current carrying curve

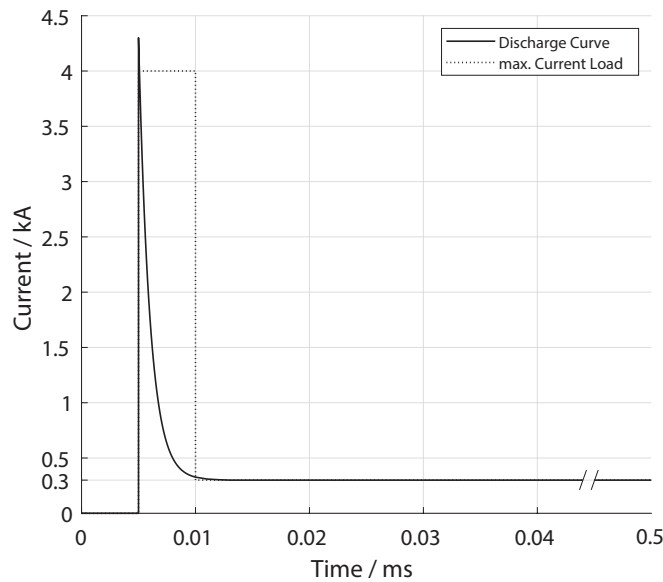

Outline dimensions*

*in mm

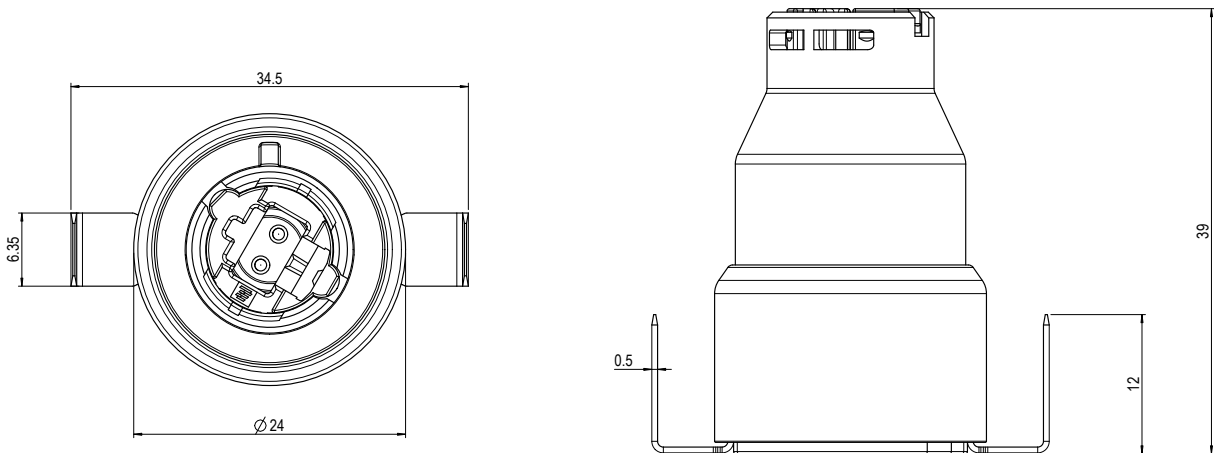

Any data, information, know-how, and any associated intellectual property shall be owned by Astotec. Astotec reserves the right to change, update or correct, without notice, the contents of this datasheet. Please note that its contents are not intended as binding specifications of the product, but rather as general information. Should you come across any errors or omissions we encourage you to contact us for further assistance. The information provided in our technical data sheets is to the best of our knowledge correct but not all-inclusive and without warranty. All rights reserved.

